

AC&M Varhour Transducer

Features:

- Dual Aux. Power 110/220V AC
- High Accuracy
0.2% RO at 23°C±5°C
- High Dielectric Strength
2.6KV AC / Min, Between Input / Output / Power Case
- ABS Plastic Case, DIN Rail or Wall Mounting

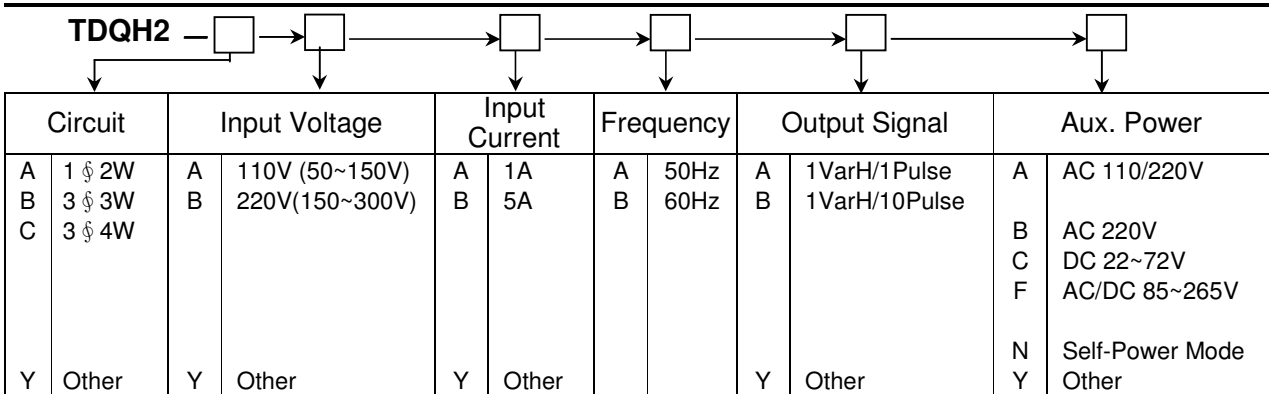

SPECIFICATIONS

Accuracy	: 0.2%RO at 23°C±5°C (Self-Power Mode 0.25%RO at 23°C±5°C).
Input Range	: Normal Voltage 110V, Effective Range 50~150V. Normal Voltage 220v, Effective Range 160~300V. Normal Current 5A, Effective Range 0~7.5A. Normal Current 1A, Effective Range 0~1.5A.
Input Burden	: 0.1VA / 60Hz at 150V AC ; Self-Power Mode 2VA at 150V AC.
Frequency	: 45 ~ 70Hz.
Input Over	: Normal AC 110V, Voltage Over 500V Continuous. Self-Power Mode 150V AC Maximum. Normal AC 5A, Current Over 15A Continuous; 50A 10 Sec / Hour ; 400A 0.5 Sec / Hour.
Output of WH & VarH	: Open Collect Type, Effective Range 5~30V DC, 5~100mA; Option Dry Contact.
Output Protection	: Without Damage for Output Open or Short Circuit.
Dielectric Strength	: 2.6KV AC / 1 Min, between Input / Power / Case.
Impulse	: 5KV 1.2X50 μ S, ANSI C37.90a/1983,DIN, IEC 255 - 4,IEC 688-1992 2.5KV - 0.25mS/1MHz IEC 801-3(Ring WAVE).
Common Mode Rejection	: > 120db, 50 / 60Hz.
Stability	: < 0.2%/Year.
Calibration	: SPAN and ZERO \pm 10%.
Response Time & Ripple(p-p)	: \leq 400mS. 0 ~ 99%; 0.5% P-P(STD) or Option.
Magnetic Effect	: DIN - IEE688 \leq 0.005% Change 10" Center 100A-Turn.
Temperature Coefficient	: \leq 100ppm / °C From 0~60°C; \leq 50ppm/23°C±3°C.
Operating Condition	: -10°C ~ +65°C 20 ~ 95% RH Non-Condensed.
Storage Condition	: -40°C ~ +75°C 20 ~ 95% RH Non-Condensed.
Power Supply	: AC or DC \pm 20%, 50 / 60Hz \leq 3VA.
Aux. Power Effect	: < 0.01% / V.
Housing Material	: ABS Plastic, Self-Extinguishing to UL Subject 94 Class V-O. Case IP 50 Snap Mounting On DIN EN 50022-35 Or Surface Mounting. Compliance With IEC 529, BS 5490, DIN 40054. Protection Touch-Proof Terminals And Enclosure Meeting Requirements Of VBG 4 & VDE 0106 part 100(Germany).
Mounting	: DIN Rail or Wall Mounting.
Size	: 120 ^W X 115 ^H X 73.4 ^L mm

* Uni-Direction and Bi-Direction for Watthour, Bi-Direction for Varhour only.

* Self-Power Mode : Effective Range 85~150V AC, Power Source from V1 Voltage.

Dimension (mm)

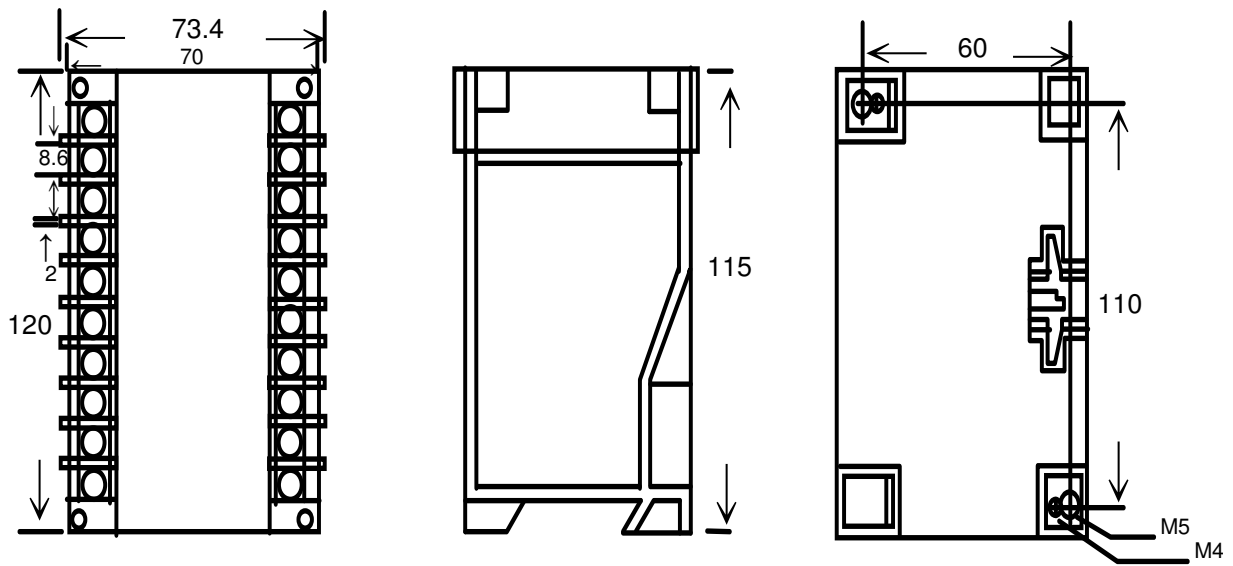

Connection Diagram Model :TDQH2

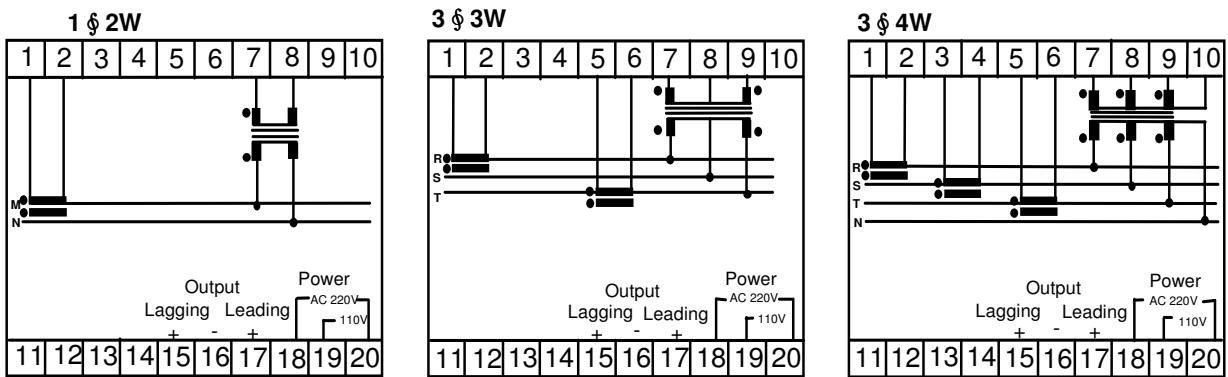

工作電源為 DC Power 時,19 + ; 20 -

For DC Power ,19+; 20-

光耦合 (Photocouple) 原理圖

