

FEATURES

- Suitable for 1 ϕ 2W / 1 ϕ 3W / 3 ϕ 3W / 3 ϕ 4W system
- Size: 96 W x 48 H x 100 D (mm)
- 8 digits display: ± 99999999 Count
- RS-485 Modbus RTU output
- Dual pulse output(Secondary value)
- Bi-direction measurement and display



FUNCTION SELECTION

MMWH - code1 code2 code3 code4 code5 code6

CODE 1		CODE 2		CODE 3		CODE 4		CODE 5		CODE 6	
INPUT VOLTAGE		INPUT CURRENT		INPUT FREQUENCY		OUTPUT 1		OUTPUT 2		AUX. POWER	
1	55-440V(L-L)	1	1A	1	50 HZ	1	Dual Pulse	1	RS-485	3	DC 22~72V
		2	5A	2	60 HZ				ModbusRTU	6	AC/DC85~265 V
						0	None	0	None		
Y	Other	Y	Other	Y	Other	Y	Other	Y	Other	Y	Other

SPECIFICATIONS

Accuracy	: $\pm 0.5\%$ RD at 23°C $\pm 3^\circ\text{C}$.	Pulse output	: Dual pulse output Corresponding to +WH / -WH 1WH 1/10/100/0.1/0.01Pulse
Display Range	: 0.4" high brightness red LED 8 digits display:: ± 99999999	Dielectric Strength	: 2.0KV 50/60HZ AC / Min Between Input / Power / Case.
Input Range	: Input 55~440V(L-L) (Max: 500V L-L) Normal Current 5A, Effective Range 0~6A. Normal Current 1A, Effective Range 0~1.5A.	Power Supply	: AC 85~265V 50 / 60Hz DC 100~300V
Input Frequency	: 45~70HZ	Dimension	: 96 W X 48 H X 100 D mm.
Input Over	: Normal AC 5A, Current Over 15A Continuous Normal AC 440V, Voltage Over 600V Continuous	Cut-out	: 92W x 44H < mm >
Digital Output Load	: RS-485 MODBUS RTU	Mounting	: Panel Flush Mounting
Baudrate	: 2400.4800.9600.19200.38400.57600	Housing Material	: ABS Plastic, Self-Extinguishing
Address	: 1~255	Operating Condition	: -10°C ~ 55°C 20 ~ 95% RH Non-Condensed.
		Storage Condition	: -40°C ~ 75°C 20 ~ 95% RH Non-Condensed.

SIZE (mm)

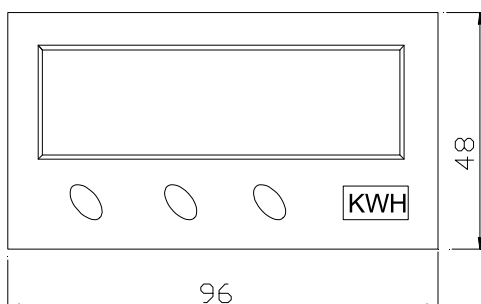

Front-view

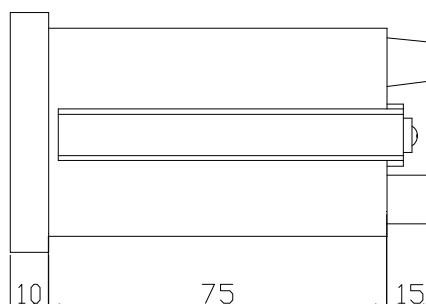

Side-view



Cut-out

TERMINALS

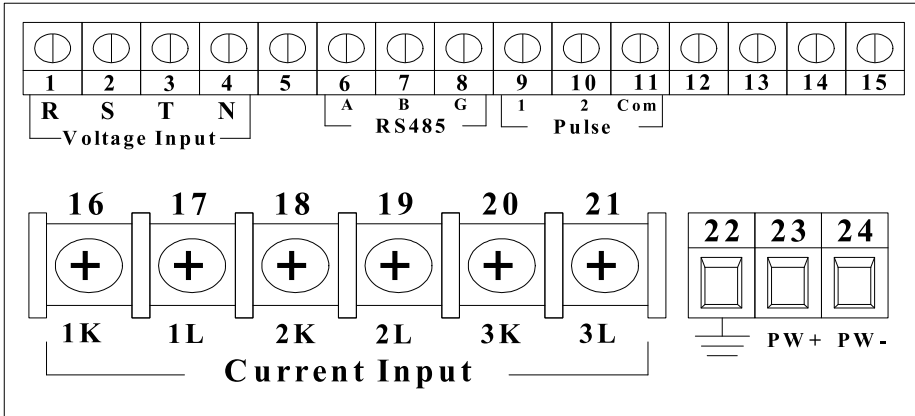

CONNECTION DIAGRAM

